

20PH Economy Tandem Dual Wheel Pintle

G.V.W.R.	20,000#	Axle	(2) 10,000# Dual Wheel Electric Brakes
G.A.W.R. (Ea. Axle)	10,000#	Supension	Multi-Leaf Slipper Spring w/Equalizer
Coupler	3" ID Pintle Ring	Tire	ST235/80 R-16 Load Range E Dual
Safety Chains	3/8" Grd. 70 w/Safety Latch Hook (2 each)	Wheel	16" x 6"; Dual Wheel 8 Bolt
Jack	Single 12,000# Drop Leg Jack (Bolted On)	Floor	2" Treated Pine or Douglas Fir*
Tongue	12" I-Beam; Integral with Frame	Lights	L.E.D. D.O.T. Stop, Tail, Turn & Clearance
Top Rail	None	Elec. Plug	7-Way RV
Frame	12" I-Beam	Finish (Prep)	Steel is Cleaned to Ensure a Professional Smooth Finish.
Crossmembers	3" Channel		
Side Rail	5" Channel w/Rub Rail, Stake Pockets on 24" Centers, and Chain Spools	FINISH	Superior Quality Finish is Applied for a Highly Decorative and Protective Finish.

* Douglas Fir Available from Caldwell, ID Facility Only

Standard Features

- 3" ID Pintle Ring
- 12,000# Drop Leg Jack- Top Wind (Bolted On)
- 102" Overall Width
- Low Profile Bed, Pierced- Beam Frame
- (2) Side Bed Steps
- 3/8" Heavy Duty Rub Rail
- Tie Down Pockets Along Sides, 24" On Center
- 1-1/4" Pipe Chain Spools Between Tie Down Pockets
- Oil Bath Hubs
- Dexter Brand Axles
- Cambered Axles
- Forward Self Adjusting Brakes
- Grommet Mount Sealed Lighting
- L.E.D. Lighting Package
- Modular Sealed Wiring Harness
- Spare Tire Mount (Inside Tongue)
- 5' Dovetail w/5' Double Hinged Flip-Over Ramps
- Complete Break-A-Way System w/Charger
- Radial Tires
- Mudflaps
- Spare Tire & Wheel- Standard Equipped **NEW!**

Description

Dimensions			
Length	A	B	C
20 + 5	240	180"	60"

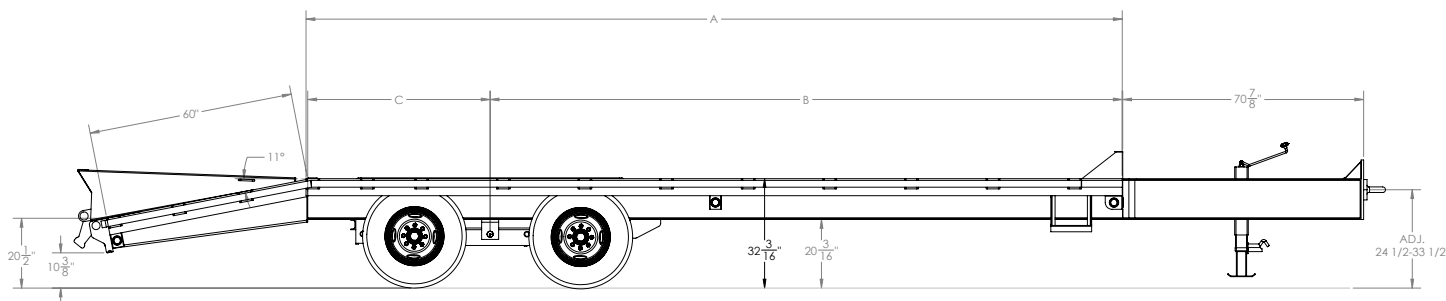

20PH Economy Tandem Dual Wheel Pintle



Model	Weight*	Description
20PH-20+5	5,100#	102" x 20' + 5' Economy Tandem Dual Wheel Pintle

Economy Model- No Additional Options Available (Black Only)

*Weights shown are for base models without options and are estimates only